

OHIO AVENUE

TECHNICAL RIDER

2008

Thank you for booking Ohio Avenue for your worship service/concert. This rider is an attempt to provide you with information that will help your event run smoothly, efficiently, and most importantly, effectively. If any areas are unclear or appear to be difficult in your particular situation, don't hesitate to contact Management with questions. We sincerely appreciate the opportunity to minister with you and are eager to help you. Please read and sign the attached rider and mail or fax it in with your contract.

Management:

Jennifer McConnell
Torn Management
9495 Brook Forest Circle
Helena, AL 35080
205.533.8903 (office)
205.533.8904 (fax)
205.492.3284 (cell)
info@tornmanagement.com

Booking Agent:

Mike Graham
Halo Productions
311 Cherokee Drive
Clanton, AL 35045
1.800.225.9087
mike@haloproductions.net

SECTION 1 - VENUE

Merchandise Area – Please provide one (1), eight-foot table for the sale of our artist merchandise.

Dressing Room Area – Please provide artist with one (1) private room where they can change clothes and pray before the event. (Sunday school rooms work fine)

Volunteers - We would like to have at least four (4) people to help us load in and set up. We will also like to have four (4) people at the end of the night to help us tear down and load out.

SECTION 2 – HOSPITALITY

Artist's personnel will be comprised of the Four (4) band members and up to two (2) crew people. All arrangements for food and lodging should be made with this information taken into consideration.

Meals – After artist arrives, please provide meals for artist and crew. To make your job easier, we have included some favorite meals below.

<p>Chicken Fingers Fries OR Mashed Potatoes & Gravy Veggie Tray Fruit Tray Ranch, Buffalo, & Honey Mustard dipping sauce Lemon Pie</p>	<p>Lasagna Salad Ranch & Honey Mustard Dressing Garlic Bread Fruit Tray NY Style Cheesecake</p>	<p>Buffet Style Taco Salad Seasoned Beef, Steak, or Chicken Chips and Tortillas Lettuce, Tomato, Cheese, Black Olives, Jalapenos, Sour Cream, Salsa Fruit Tray Lemon Pie</p>	<p>Chicken Pot Pie Green Beans English Peas Fruit Tray Veggie Tray NY Style Cheesecake</p>
<p>Grilled Chicken Breast Green Beans Mashed Potatoes with gravy OR Macaroni & Cheese Salad Ranch & Honey Mustard Dressing Bread Fruit Apple Pie</p>	<p>Pot Roast Potatoes Carrots Mexican Cornbread Salad Ranch & Honey Mustard Dressings Fruit Apple Pie</p>	<p>BBQ BBQ Chicken/Pork or Ribs Buns Baked Beans Potato Salad Cole Slaw Fruit Lemon Pie</p>	<p>Grilled Chicken Alfredo Pasta Steamed Brocoli Garlic Bread Salad Ranch & Honey Mustard Dressings Fruit Tray NY Style Cheesecake</p>

Take out food from restaurants is also welcome, but please take orders from the band when they arrive and send someone out to pick it up.

To avoid having band members eating the same meals every day, we ask that you follow the schedule below based on the day of the week that your event takes place. If this is inconvenient for you please feel free to contact artist management. We are happy to work out another meal option for your event!

MONDAY	TUESDAY	WEDNESDAY	THURSDAY	FRIDAY	SATURDAY	SUNDAY
Chicken Fingers or Lasagna	Taco Salad or Chicken Pot Pie	Chicken Fingers or Lasagna	Grilled Chicken or Pot Roast	Taco Salad or Chicken Pot Pie	Grilled Chicken or Pot Roast	BBQ or Grilled Chicken Alfredo

Snacks - Also, please have a few snacks in artist's dressing room area throughout the day. Some favorites are fruit trays, Pringles (salt & vinegar or barbeque), Sun Chips, Beef Jerky, Nutter Butter, Reese Cups, and Oreos. Please also provide artist with 1 loaf of whole wheat bread, 1 pack of sandwich meat (turkey or ham), and one pack of sandwich cheese.

Beverages – Please provide a wide assortment of beverages to be kept on hand throughout the entire day from Artist's arrival through their departure. This should include at least 24 bottles of water. Other favorites are Gatorade, Starbucks Frappuccinos (mocha or vanilla), Jones or IBC Cream Soda, and Milo's Sweet Tea.

SECTION 3 – LODGING

If overnight lodging is needed for the event:

Please provide two (2) rooms (1 with two double beds, 1 with a one king or queen bed, both non-smoking) at a nearby good quality hotel or motel. These rooms should be reserved and paid for in advance by the Purchaser. We ask that you also pre-pay for Internet access whenever possible. The rooms should be held under the name Derek Williams.

On occasion, the band may need to drive part of the way to their next location after your event. If so, you will need to provide the band with the cash value of the hotel rooms instead of booking the rooms.

SECTION 4 – PRODUCTION REQUIREMENTS

- A. **Sound System** - a mixer/amplification/speaker system that is of good quality and that is capable of providing adequate sound for the venue.
- B. **Mixing Console** - one professional quality mixing console with at least 8 input channels, each input channel should have a minimum of a four band semi-parametric EQ.
- C. **Main Speakers** – at least 2 main speakers (15" and a horn)
- D. **Sub Speakers** – at least 2 sub woofers (18")
- E. **Monitors** – at least four stage monitors (12" and a horn)
- F. **Amps** – power amps capable of powering the above sound system
- G. **Misc** - All microphones, cables and stands that are called for in the attached input list
- H. **Sound Operator** – a qualified technician to set up and operate the PA system under the Artist's supervision and direction
- I. **Staging** - Please make sure that the stage area is cleared of obstructions and equipment prior to load-in (i.e. podiums, pulpits, drum sets, piano, etc.)

OHIO AVENUE INPUT LIST

CHANNEL	INPUT	MIC TYPE	STAND TYPE
1	Kick	Beta 52	Short Boom
2	Snare	SM 57	Boom
3	High Hat	SM 57	Boom
4	Tom 1	SM 57	Boom
5	Tom 2	SM 57	Boom
6	Tom 3	SM 57	Boom
7	Overhead left	SM 81	Tall Boom
8	Overhead right	SM 81	Tall Boom
9	Bass	DI	N/A
10	Casey Electric Lead	SM57	Short Boom
11	Derek Electric rhythm	SM57	Short Boom
12	Derek Keyboard	DI	N/A
13	Casey Vocal	SM 58	Boom
14	Derek Vocal (lead)	Prefers wireless mic or SM 58	2 Boom stands
15	Bass Vocal	SM 58	Boom

All the microphones listed may not be needed in smaller venues

OHIO AVENUE STAGE PLOT

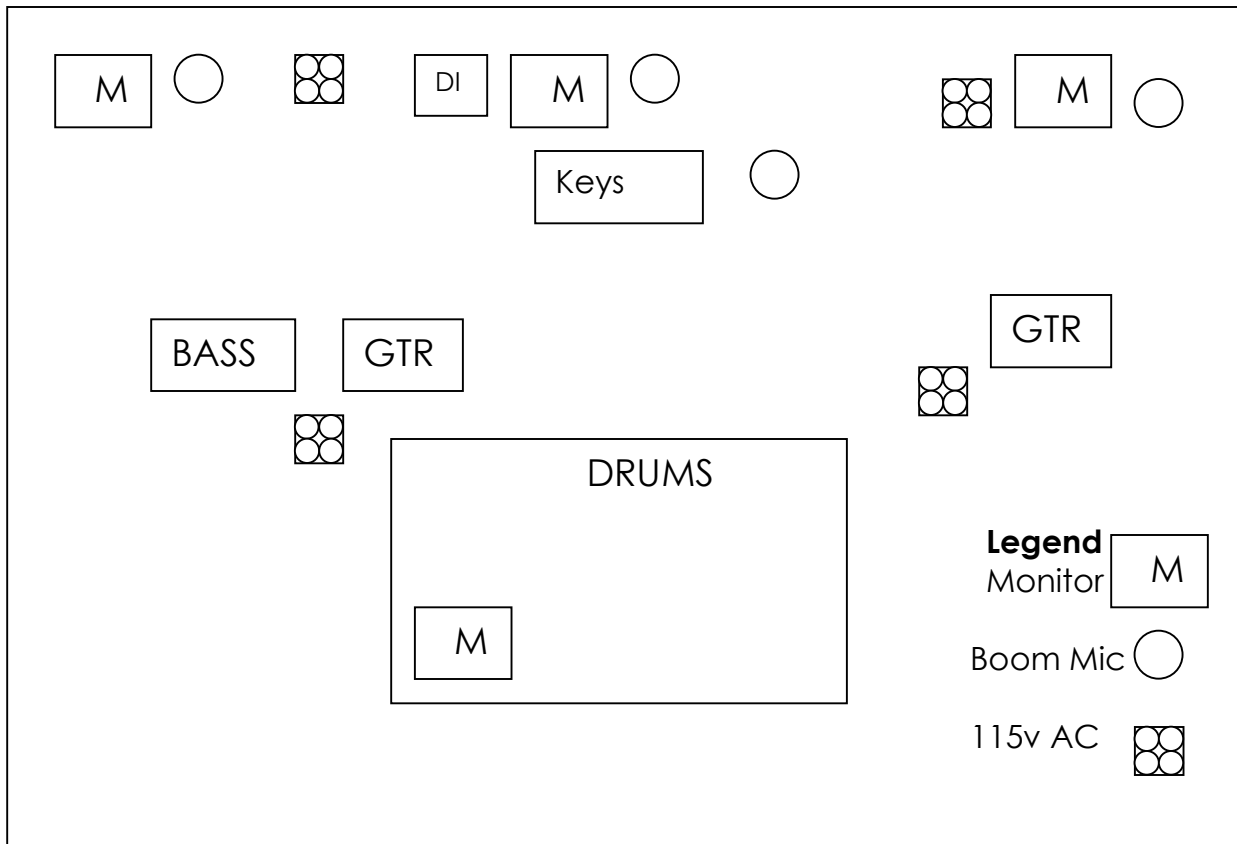

SECTION 5 – FEES

All payments on behalf of the band should be made via cash or check. Checks should be made payable to **Ohio Avenue**. The band should be paid on the day of the performance.

CONTRACT CONFIRMATION

I, the Purchaser, have read and understand that this rider is to be treated as part of the legally binding performance contract that I have entered into with Ohio Avenue. By signing below, I agree to fulfill the requirements laid out for me in this contract. I understand that if I have any questions or problems regarding this rider, I will contact Ohio Avenue well in advance of the date of the event.

Purchaser Representative

Date